

# **BULL**

***Outdoor Products Inc.***



## ASSEMBLY & OPERATING INSTRUCTIONS

MODEL #18248 BULL 7 BURNER STAINLESS STEEL, ROTISSERIE, BUILT-IN, L.P. (PROPANE)

MODEL #18249 BULL 7 BURNER STAINLESS STEEL, ROTISSERIE, BUILT-IN, N.G. (NATURAL GAS)

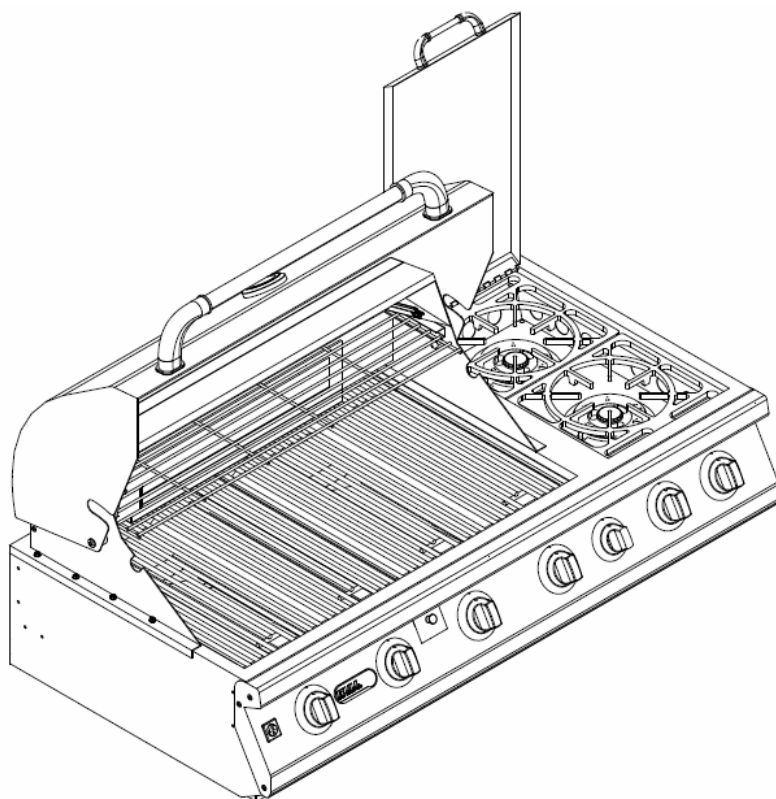

**CE**

# TABLE OF CONTENTS

PAGE #

SAFETY INSTRUCTIONS.....	2
<i>THE LOCATION FOR YOUR GRILL.....</i>	2
<i>CHECKING FOR GAS LEAKS.....</i>	2
<i>NATURAL GAS SAFETY.....</i>	3
<i>PROPANE GAS SAFETY.....</i>	4
INSTALLATION INSTRUCTIONS.....	5
<i>SPECIFICATIONS FOR BARBECUE STRUCTURE.....</i>	5
<i>CONNECTING TO GAS SOURCE.....</i>	5
<i>NATURAL GAS CONNECTIONS.....</i>	5
<i>PROPANE GAS CONNECTIONS.....</i>	5
<i>OUTDOOR NATURAL GAS BBQ INSTALLATION SPECIFICATIONS.....</i>	6
<i>OUTDOOR PROPANE GAS BBQ INSTALLATION SPECIFICATIONS.....</i>	7
<i>TRANSFORMER.....</i>	8
INSPECTING / CLEANING BURNERS AND GAS VALVE ORIFICES.....	9
<i>BURNER CLEANING.....</i>	9
<i>BURNER SHUTTER CLIP INSPECTION / ADJUSTMENT.....</i>	9
<i>BURNER REPLACEMENT INTO INSERT.....</i>	10
<i>IGNITOR / ELECTRODE CHECK.....</i>	10
<i>BURNER OPERATION CHECK.....</i>	10
COOKING COMPONENT INSTALLATION.....	12
LIGHTING & OPERATING INSTRUCTIONS.....	13
<i>LIGHTING PROCEDURES.....</i>	13
<i>OPERATING PROCEDURE.....</i>	14
<i>COOKING TEMPERATURES.....</i>	14
ROTISSERIE COOKING.....	16
<i>LIGHTING &amp; OPERATING INSTRUCTIONS.....</i>	17
LIGHT SYSTEM.....	18
<i>LIGHT BULB REPLACEMENT.....</i>	18
CLEANING & MAINTENANCE.....	20
TROUBLESHOOTING.....	21
<i>IF GRILL FAILS TO OPERATE PROPERLY.....</i>	21
<i>YELLOW FLAME.....</i>	22
<i>FLASH BACK.....</i>	22
PARTS LIST.....	23
EXPLODED ILLUSTRATION.....	25
LIMITED WARRANTY.....	26

- READ THE FOLLOWING INSTRUCTIONS CAREFULLY AND BE SURE YOUR GRILL IS PROPERLY INSTALLED, ASSEMBLED AND CARED FOR. FAILURE TO FOLLOW THESE INSTRUCTIONS MAY RESULT IN SERIOUS BODILY INJURY AND/OR PROPERTY DAMAGE. IF YOU HAVE QUESTIONS CONCERNING ASSEMBLY OR OPERATION, CONSULT YOUR DEALER, GAS APPLIANCE SERVICE REPRESENTATIVE OR YOUR GAS COMPANY.

- NOTE TO INSTALLER:

LEAVE THESE INSTRUCTIONS WITH THE CONSUMER AFTER INSTALLATION.

- NOTE TO THE CONSUMER:

RETAIN THESE INSTRUCTIONS FOR FUTURE REFERENCE.

- THIS OUTDOOR COOKING GAS APPLIANCE IS NOT INTENDED TO BE INSTALLED IN OR ON RECREATIONAL VEHICLES AND/OR BOATS.

\*FOR WARRANTY PURPOSES, PLEASE RECORD YOUR MODEL NUMBER, SERIAL NUMBER, DATE OF PURCHASE & A COPY OF YOUR RECEIPT OR INVOICE IN THE BACK OF YOUR MANUAL ON PAGE 26.

NOMINAL HEAT INPUT: MAIN BURNER: 4.39 kW, ROTISSERIE BURNER: 4.39 kW, SIDE BURNER: 4.39 kW. FOR GAS CATEGORIES 12E(20), 12H(20), 13B/P(50), 13B+(28+37), 13B/P(30): NATURAL & LP GASES 240VAC, 50Hz INPUT.



# SAFETY INSTRUCTIONS

## READ CAREFULLY BEFORE ASSEMBLY AND OPERATION OF YOUR GRILL

This gas grill must be installed in accordance with local codes or, if in an area without local codes, with the latest edition of the National Fuel Gas Code ANSI Z223.1. In Canada, installation must conform to the standard CAN/CGA 1-b149.1 and/or .2 (Installation Code for Gas Burning Appliances and Equipment) and any local codes. Outside the United States, installation must conform with the latest edition of CE Norms EN498.

*Outdoor Products Inc.*

**WARNING:** Fuels used in gas or oil-fired appliances and the products of combustion of such fuels, contain chemicals known to the State of California to cause cancer, birth defects and/or reproductive harm. This warning is issued pursuant to California Health & Safety Code Sec. 25249.6.

## THE LOCATION FOR YOUR GRILL

**DO NOT** use your gas grill in garages, porches, breezeways, sheds or other enclosed areas. Your gas grill is to be used **OUTDOORS ONLY**, with at least **21 inches/54 cm** clearance from the back and side of any combustible surface. The grill should not be placed under or on top of any surface that will burn. Do not obstruct the flow of combustion and ventilation air around the grill housing.

**PROTECT CHILDREN:** Keep children away from the grill during use and until the grill has cooled after you are finished. Do not allow children to operate the grill.

### FOR YOUR SAFETY...

**DO NOT** store or use gasoline or other flammable vapors and liquids in the vicinity of this or any other appliance.

**DO NOT** store empty or full spare gas cylinders and/or chemicals under or near this or any other appliance.

Keep the fuel hose and electrical cord away from hot surfaces. Protect the fuel hose from dripping grease. Avoid unnecessary twisting of the hose. Visually inspect the hose prior to each use for cuts, cracks excessive wear or other damage and replace if necessary.

**NEVER** test for gas leaks with a lighted match or open flame.

**NEVER** light grill with lid closed or before checking to ensure burner tubes are fully seated over gas valve orifices.

**NEVER** lean over cooking surface while lighting grill. Use barbecue tools with wood handles and good quality insulated oven mitts when operating grill.

### IF YOU SMELL GAS...

1. Shutoff gas to the appliance at its' source.
2. Extinguish any open flame.
3. Open grill lid to release any accumulation of fumes.
4. If gas odor persists, immediately contact your gas supplier.

## CHECKING FOR GAS LEAKS

**NEVER TEST FOR GAS LEAKS WHILE THE GRILL IS LIT!** Prior to the first use and at the beginning of each new season (or, if using LP, whenever gas cylinder is changed), it is a must that you check for gas leaks. Follow these steps:

1. Make a soap solution by mixing one part liquid detergent and one part water.
2. Turn off heat control valve(s), and then turn on gas at source.
3. Apply the soap solution to all gas connections: bubbles will appear in the soap solution if connections are not properly sealed. Tighten or repair as necessary.
4. If you have a gas leak that you cannot repair, turn off the gas at the source, disconnect fuel line from the grill and immediately call your grill dealer and gas supplier for professional assistance.

# SAFETY INSTRUCTIONS (CONT.)

## NATURAL GAS SAFETY

Your Natural Gas (G20) grill is designed to operate on natural gas ONLY, at a pressure of 4" water column (W.C.)/10 mbar regulated at the natural gas regulator attached at the back of the grill. Check with your gas utility for local gas pressure and with your local municipality for building code requirements.

*BULL*  
*Outdoor Products Inc.*

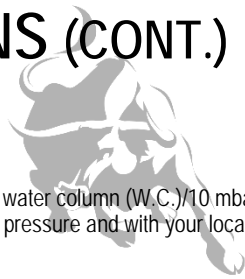

Check with your gas utility or with local building codes for instructions to install gas supply line, or call a licensed and knowledgeable installer.

It is recommended that an "ON-OFF" shutoff valve be installed at the gas supply source:

- Outdoors after gas line piping exits outside wall and before quick-disconnect or before gas line piping enters ground.
- Indoors in the branch fuel line in an accessible location near the supply line.

Pipe sealing compound or pipe thread tape of the type resistant to the action of natural gas must be used on all male pipe thread. Apply compound or tape to at least the first three threads when making the connection.

Disconnect your gas grill from fuel source when the gas supply is being tested at high pressures. This appliance and its individual shutoff valve must be disconnected from the gas supply piping system during any pressure testing of that system at pressures in excess of 1/2 psig (3.5 kPa)/37 mbar.

Turn off your gas grill when the gas supply is being tested at low pressures. This appliance must be isolated from the gas supply piping system by closing its individual valve.

**WARNING:** Gas valves are preset at the factory to operate on LP or natural gas. If you wish to convert to a different gas type, be sure to contact your grill dealer, licensed plumber or authorized service center for further details. Conversion kits are not sold to the general public and require a professional to perform service. Failure to properly convert a unit can cause serious injury to yourself and/or others, irreparable damage to your grill and void of warranty.

## SAFETY!

## BEWARE OF SPIDERS



**CAUTION: BURNERS MUST BE INSPECTED AND CLEANED BEFORE FIRST USE.**

Spiders and small insects occasionally spin webs or make nests in the burners during warehousing, transit and/or after long periods of non-use. These webs can lead to a gas flow obstruction, which could result in a fire in and around the burner tubes. This type of fire is known as "FLASH-BACK" and can cause serious damage to your grill and create an unsafe operating condition for the user. Although an obstructed burner tube is not the only cause of "FLASH BACK" it is the most common cause, and frequent inspection and cleaning of the burners is necessary.

# SAFETY INSTRUCTIONS (CONT.)

## PROPANE GAS SAFETY

Your Propane gas (G31) grill is designed to operate on propane gas ONLY, at a pressure regulated at 11" water column (W.C.)/27.4 mbar when equipped with the correct propane orifices on the valves and a propane regulator on the supply line regulated at the residential meter.

*BULL*  
*Outdoor Products Inc.*

Your propane gas grill is designed to be used with a standard 20 lb/7 kg gas cylinder. In the United States, the gas cylinder must be constructed and marked in accordance with specifications of the US Department of Transportation for Propane Gas Cylinders. Outside the United States, the gas cylinder must be approved under CE NORMS: EN417 and test code 215. Gas cylinder must be constructed and marked with CE regulations for the European country of destination, where it will be used.

Always keep cylinder securely fastened in an upright position.

Never connect an unregulated propane gas cylinder to the grill.

Do not subject Propane cylinders to excessive heat.

CAUTION: Never store a Propane gas cylinder inside a building or in the vicinity of any gas-burning appliance.

WARNING: Gas valves are preset at the factory to operate on LP or natural gas. If you wish to convert to a different gas type, be sure to contact your grill dealer, licensed plumber or authorized service center for further details. Conversion kits are not sold to the general public and require a professional to perform service. Failure to properly convert a unit can cause serious injury to yourself and/or others, irreparable damage to your grill and void of warranty.

## SAFETY!

## BEWARE OF SPIDERS



CAUTION: BURNERS MUST BE INSPECTED AND CLEANED BEFORE FIRST USE.

Spiders and small insects occasionally spin webs or make nests in the burners during warehousing, transit and/or after long periods of non-use. These webs can lead to a gas flow obstruction, which could result in a fire in and around the burner tubes. This type of fire is known as "FLASH-BACK" and can cause serious damage to your grill and create an unsafe operating condition for the user. Although an obstructed burner tube is not the only cause of "FLASH BACK" it is the most common cause, and frequent inspection and cleaning of the burners is necessary.

## WARNING

- Do not store a spare or disconnected liquid propane cylinder under or near this barbecue.
- A dented or rusty liquid propane cylinder may be hazardous and should be checked by your liquid propane provider.
- Do not use a liquid propane cylinder with a damaged valve.

# INSTALLATION INSTRUCTIONS

PLEASE READ THESE INSTRUCTIONS BEFORE INSTALLING YOUR GAS GRILL

Your Built-in Gas Grill comes to you fully assembled. We strongly recommend professional installation and hookup of the Gas BBQ grill. These instructions will provide you with the measurements necessary for you or your builder to construct a masonry structure to house your outdoor gas grill.

**NOTE TO INSTALLER:** Leave these instructions with the consumer for future reference. The grill must be installed in accordance with all local building codes. Adapter from 1/2" NPT to BSP 21 mm & regulator are available from Bull dealers and distributors.

## SPECIFICATIONS FOR BARBECUE STRUCTURE

1. Your choice of masonry can be used for cabinet construction for the built-in gas grill; however it must be **non-combustible** material. Keep in mind when choosing a location for your grill that it should NOT be located under any overhead combustible construction. Upper and ground level vents must be provided for combustion air on both sides of built-in cabinet. Vents on BBQ insert must remain unobstructed to allow for combustion air and ventilation.
2. The BBQ grill requires a wall opening of the following dimensions: See **PAGES 6 & 7 for different models**.
3. Place gas grill assembly into wall opening as shown in illustration on pages 6 & 7. BBQ rests on side and back edges of the BBQ insert.
4. For propane gas LP TANK STORAGE AREA MUST BE ISOLATED FROM GRILL AND VENTED.
5. Do not use any combustible materials for this construction. Minimum horizontal clearance to adjacent combustible surface from side and back of the grill must be 21 inches/54 cm. A 6 inch clearance is required behind grill to allow front portion of hood to open and for ventilation purposes.

## CONNECTING TO GAS SOURCE

Refer to the following instructions and illustrations for typical gas supply connections. We strongly suggest professional installation and hook-up of the Gas BBQ.

**IMPORTANT:** Before connecting grill to gas source, make sure BBQ Grill control knobs are in "OFF" position.

## NATURAL GAS CONNECTIONS

- Pipe sealing compound or pipe thread tape of the type resistant to the action of natural gas must be used on all male pipe thread.
- Apply compound or tape to at least the first three threads when making the connection.
- Remove plastic cap from regulator installed on grill.
- Attach stainless steel flex line 3/8"/9.5 mm flare-female end to the regulator.
- Attached the other end of flex line to shut-off valve through a nipple.
- Attach a shut-off valve to gas supply pipe.

PERFORM GAS LEAK CHECK – REFER TO PAGE 2

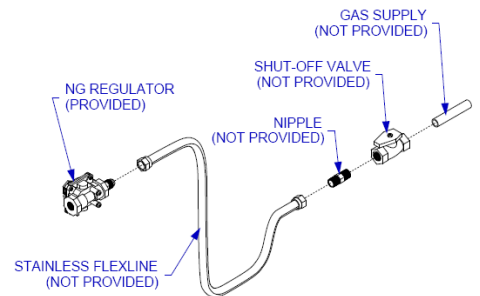

## PROPANE GAS CONNECTIONS

- In the United States, the LP gas pressure regulator and hose assembly supplied with this unit must be used without alteration. If this assembly needs to be replaced, use only the type 1 specified in the parts list supplied with this unit. Use a LP tank with a type 1 cylinder valve.
- Outside the United States, the LP gas pressure regulator is not supplied with the grill but Cavagna Group BS3016 Type 634PR regulator or equivalent can be purchased from Bull dealers or hardware stores.
- Make sure the tank is firmly secured in an upright position.
- Turn the black coupling nut of the hose and regulator assembly in a clockwise direction.
- Make sure it is completely threaded onto the cylinder valve before turning gas supply on.

PERFORM GAS LEAK CHECK – REFER TO PAGE 2

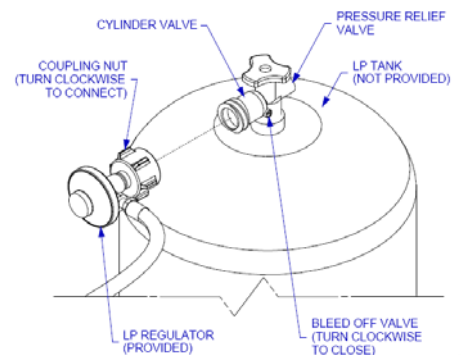

# INSTALLATION INSTRUCTIONS (CONT.)

## OUTDOOR NATURAL GAS BBQ INSTALLATION SPECIFICATIONS

### NOTE:

- Vents must be provided for combustion air and ventilation on both sides of built-in cabinet.
- When choosing a location for your gas grill keep in mind that it should never be located under any overhead combustible construction.
- The sides and back of the grill should not be any closer than **21 inches/54 cm** to combustible construction.
- **DO NOT** store empty or full spare tanks under or near this or any other appliance.
- There must be a minimum of **6"** counter space behind the grill in order to allow the grill hood to clear properly.

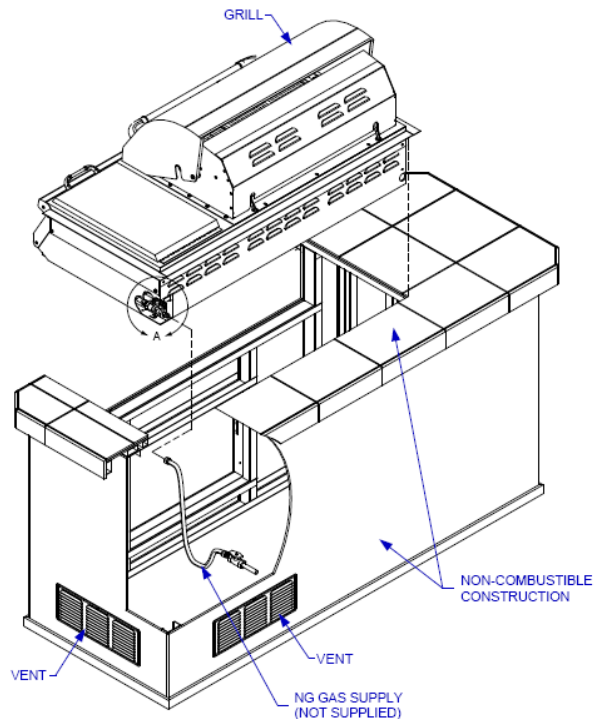
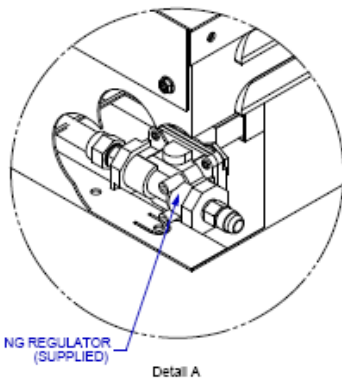
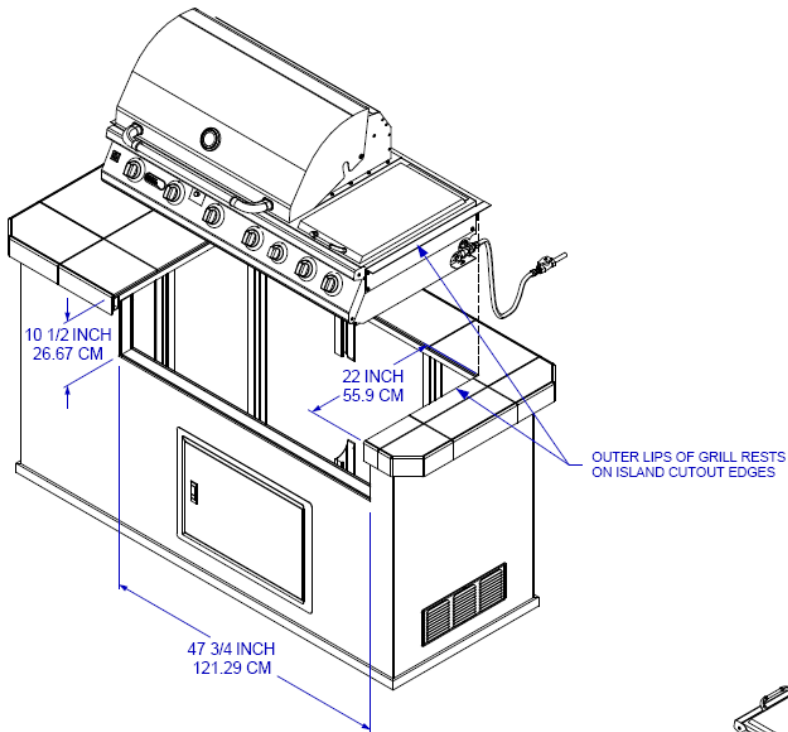

# INSTALLATION INSTRUCTIONS (CONT.)

## OUTDOOR PROPANE GAS BBQ INSTALLATION SPECIFICATIONS

### NOTE:

- Vents must be provided for combustion air and ventilation on both sides of built-in cabinet.
- When choosing a location for your gas grill keep in mind that it should never be located under any overhead combustible construction.
- The sides and back of the grill should not be any closer than **21 inches/54 cm** to combustible construction.
- **DO NOT** store empty or full spare tanks under or near this or any other appliance.
- There must be a minimum of **6"** counter space behind the grill in order to allow the grill hood to clear properly.

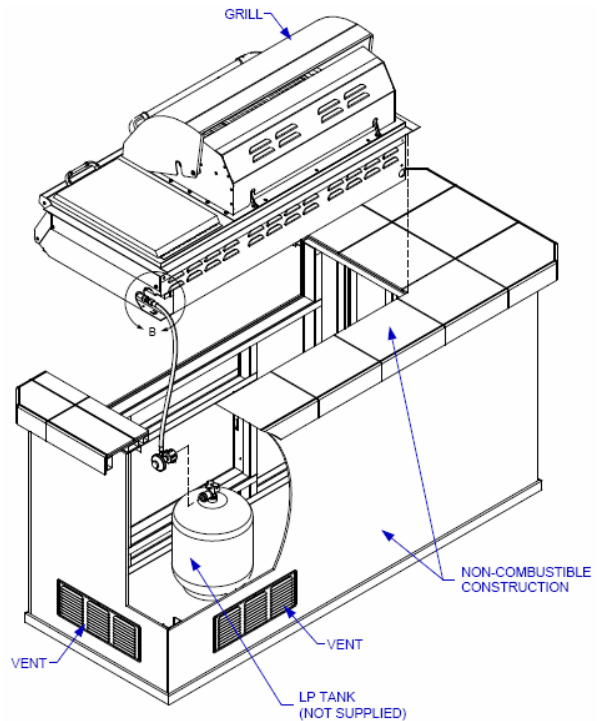
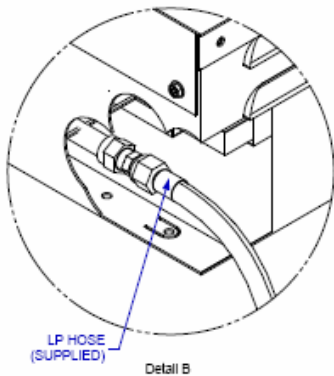
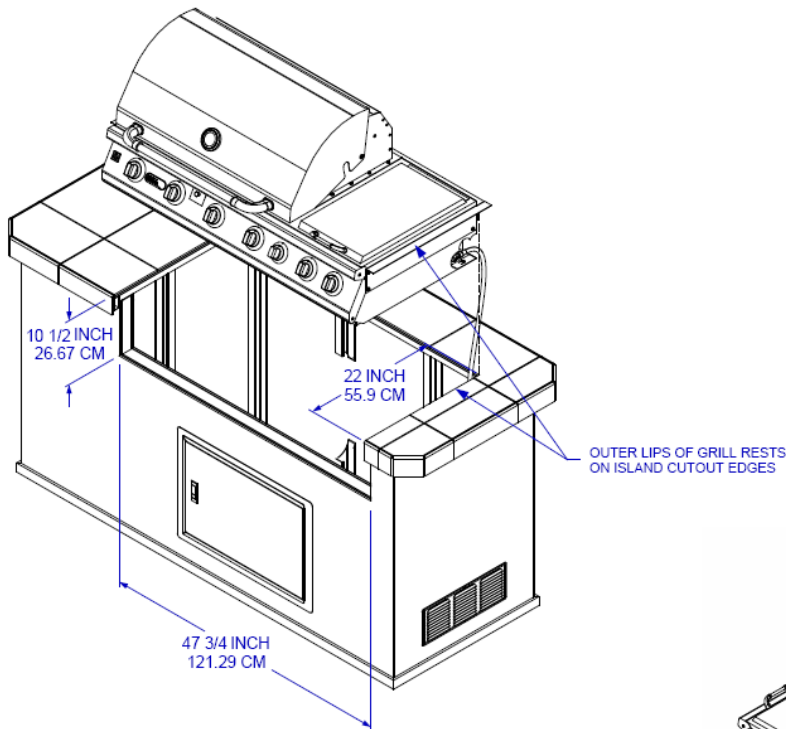



# INSTALLATION INSTRUCTIONS (CONT.)

## TRANSFORMER

In order to ensure transformer and interior light system longevity, the transformer must be installed at least 6" above the ground. The transformer may be attached to your island material using metal screws. To install your transformer, secure two screws (not provided) through the designed mounting tabs (see illustration below).

**BULL**  
Outdoor Products Inc.

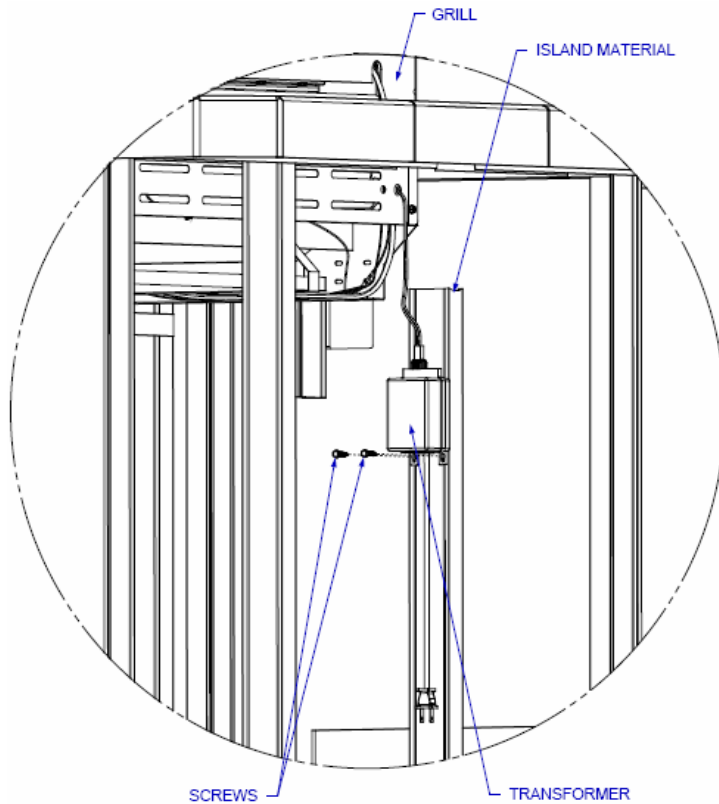
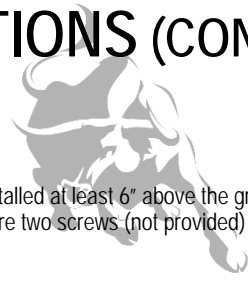

# INSPECTING / CLEANING BURNERS AND GAS VALVE ORIFICES



By following these cleaning procedures on a timely basis, your grill will be kept clean and working properly with minimum effort.

**CAUTION – Always turn off the gas supply prior to clearing your grill.**

## BURNER CLEANING

1. Remove burner from the grill insert (See drawing below). Bend a stiff wire (a light-weight coat hanger works well) into a small hook as shown to the right. Run the hook through each burner tube and burner several times. 

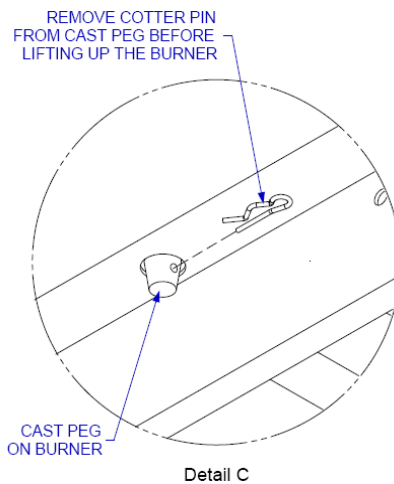
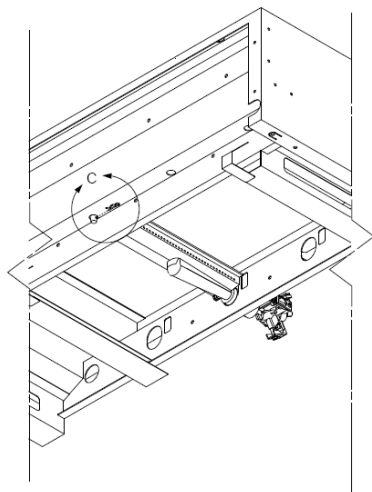

2. Use a narrow bottlebrush with a flexible handle. Run the hook through each burner tube and burner several times.
3. Wire brush entire outside surface of burner to remove loose corrosion.
4. Clean any clogged hole with a stiff wire (such as an open paper clip).
5. Inspect the burner assembly for any openings caused by corrosion.

## GRILL BURNER AND SIDEBURNER SHUTTER CLIP INSPECTION / ADJUSTMENT

The grill burners and sideburner ventri tubes are set to a factory setting; however the air to fuel mixture may need to be adjusted to accommodate different gas pressures. In order to adjust the air to fuel mixture, loosen the screw and rotate the shutter clip to the appropriate setting (see diagrams below). Tighten the screw and repeat adjustment procedure to the remaining grill burners and sideburner ventri tubes. This should improve burner efficiency.

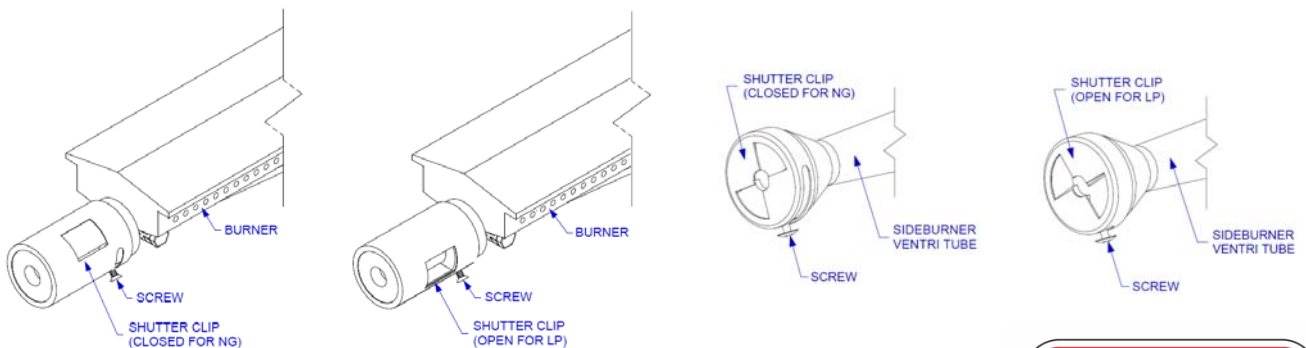

# INSPECTING / CLEANING BURNERS AND GAS VALVE ORIFICES (CONT.)

## BURNER REPLACEMENT INTO INSERT

*Outdoor Products Inc.*

**CAUTION** – Always turn off the gas supply prior to clearing your grill.

1. Replace burner back into the grill insert. There is no need to replace the cotter pin back into the cast peg, it is for shipping purposes only.
2. Check the burner for proper location after replacing. **Make sure the valve orifices are inside of the burner tubes (see drawing below).** If the valve orifices do not fit inside the burner tubes, lighting the burners may cause explosion and/or fire.

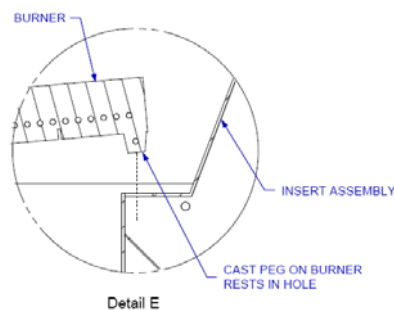
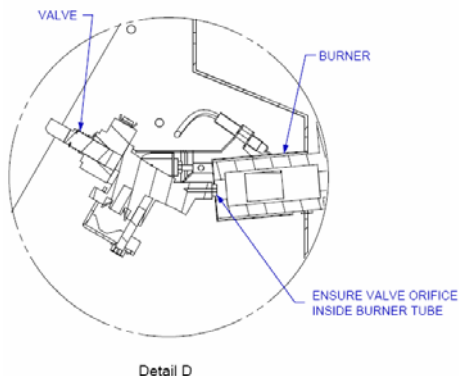
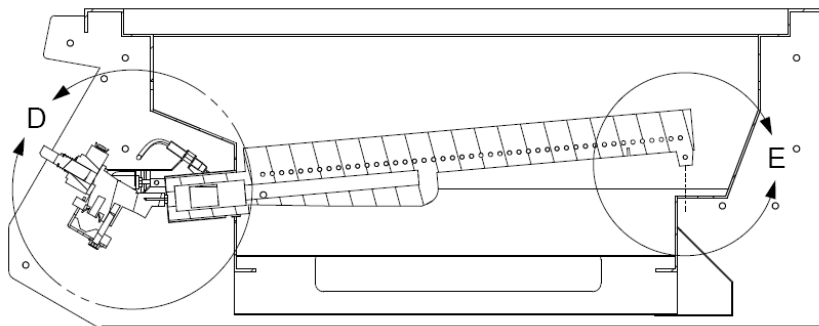

## IGNITOR / ELECTRODE CHECK

With all control knobs set to "OFF", check each igniter individually for presence of spark at electrode. In turn, push each control knob in fully and turn slowly about a 1/4 turn to the left (counter-clockwise) until a click is heard; the trigger hitting the strike block should produce a blue spark at the electrode tip. Return control knob to "OFF" before checking next igniter.

## BURNER OPERATION CHECK

**NOTE:** Upon first assembly the gas lines and burners will be full of air. In order for the burners to light properly the lines must fill with gas. It may require several attempts at lighting the burners before you are successful.

1. With BBQ Grill control knobs in "OFF" position, turn on the Gas supply.

# INSPECTING / CLEANING BURNERS AND GAS VALVE ORIFICES (CONT.)

2. Light any burner by pushing its control knob in fully and slowly (3 to 4 seconds) turning it about 1/4 turn to the left (counter-clockwise) until a click is heard. The 3 to 4 second duration should provide enough gas to light the burner. If the burner does not light, immediately return the control knob to "OFF", wait several minutes for the gas to disperse, and repeat the process. After burner lights successfully, turn control knob to "OFF".

3. Repeat process for each control knob/igniter, in turn, ensuring that other knobs are in "OFF" position as you perform each check.

4. If any burners fail to light after several attempts, discontinue gas supply at source and re-inspect for obstructions to gas flow and orifices.

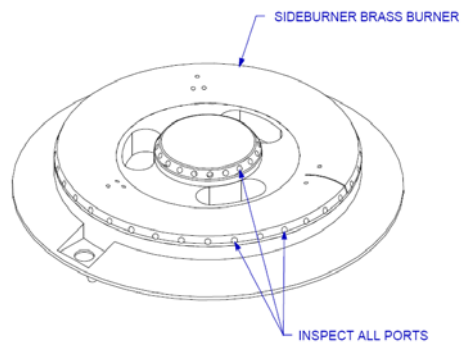
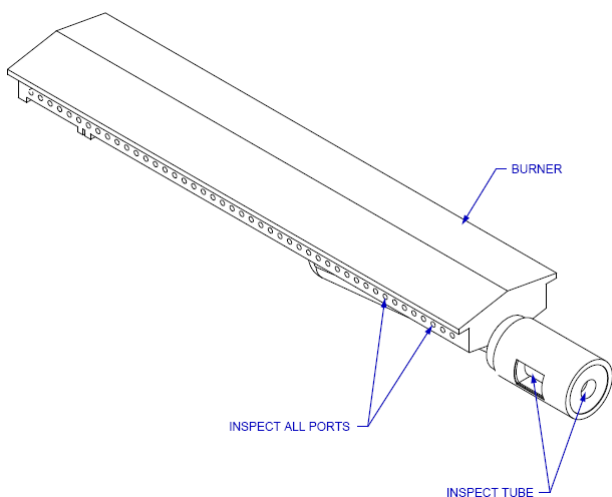
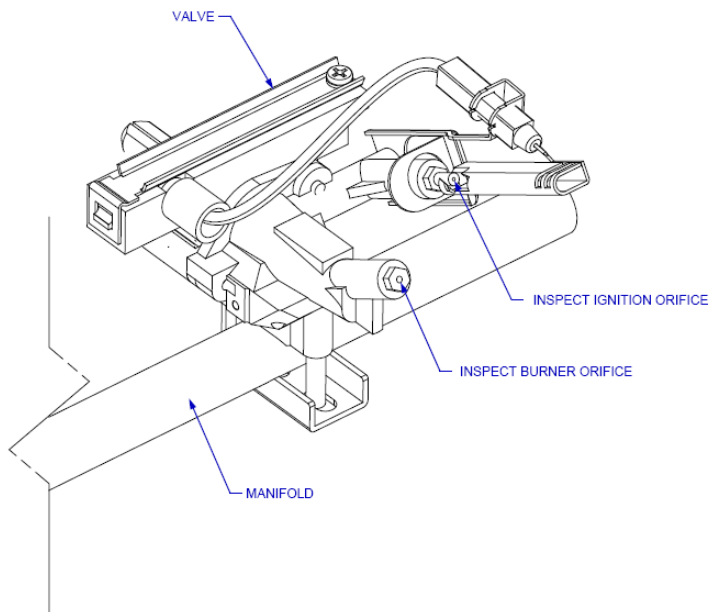

# COOKING COMPONENT INSTALLATION

**IMPORTANT:** Before first use: wash flame tamers, cooking grids, and warming rack with warm, soapy water. Rinse and dry thoroughly. Season metal surfaces with cooking oil occasionally. (After cooking is completed, turn grill to high setting for NO MORE THAN five minutes to burn off excess grease or food residue)

**CAUTION: DO NOT LEAVE GRILL UNATTENDED WHILE GRILL IS IN USE**

1. Place stainless steel heat shields on lowest ledge under / between burners in grill insert (see drawing to the right).

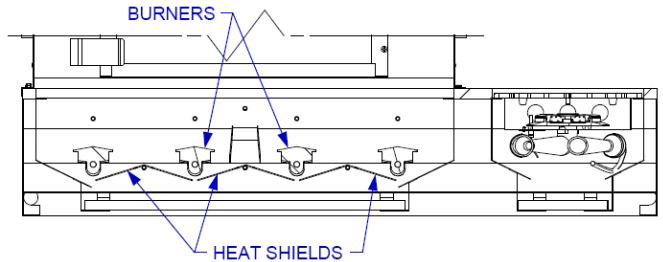

2. Place stainless steel burner flame tamers on lower ledge above burners in grill insert. Place stainless steel smoker box flame tamer on the higher ledge above the grill smoker box (see drawing to the right).

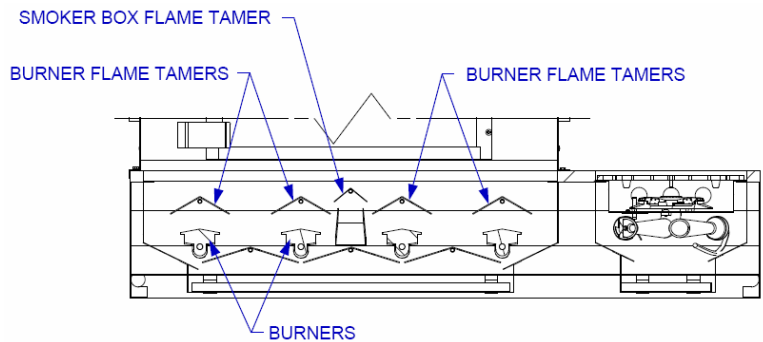

3. Place cooking grids in grill insert on ledge above flame tamers (see drawing to the right).

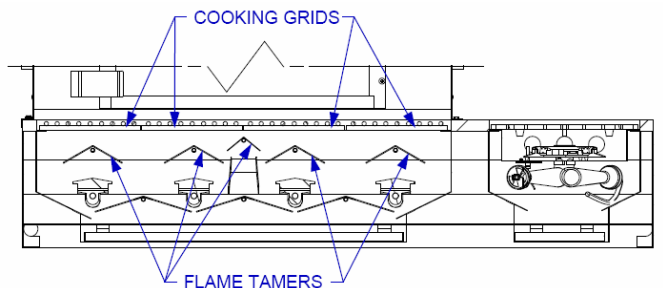

**NOW YOUR GAS GRILL IS READY TO USE!**

Before first use and at the beginning of each barbecue season:

1. Please read Safety, Lighting and Operating Instructions carefully.
2. Check gas valve orifices, burner tubes and burner ports for any obstructions.
3. PERFORM GAS LEAK CHECK – REFER TO PAGE 2.

# LIGHTING & OPERATING INSTRUCTIONS

## LIGHTING PROCEDURES

### Lighting Main Burner(s):

1. Become familiar with the safety guidelines at the front of the manual. **DO NOT SMOKE WHILE LIGHTING GRILL OR CHECKING GAS SUPPLY CONNECTIONS!**
2. If your grill fuel source is a LP gas cylinder, check to see that cylinder is filled.
3. Check that the end of each burner tube is properly located over each valve orifice.
4. Make sure all gas connections are securely tightened. **TEST FOR LEAKS WITH A SOAP SOLUTION, NEVER WITH A FLAME.** (Gas Leak Check instructions are on page 2).
5. Always open lid before lighting.
6. Set ALL BBQ Grill control knobs to "OFF" and open gas supply, LP cylinder or Natural Gas Valve.
7. Ignite only the burners you intend to use, using the same method for each: Push in control knob completely and rotate slowly (3 to 4 seconds) about 1/4 turn to the left (counter clockwise) until a click is heard. The 3 to 4 second duration should provide enough gas to light the burner. If the burner does not light, immediately return the control knob to 'OFF', wait several minutes for the gas to disperse, and repeat the process. After burner ignites, repeat procedure with any other burner needed.
8. Adjust control knob(s) to desired cooking temperature.

**NOTE:** If igniters fail to produce a spark at the electrode tip, burners can be manually lit with a fireplace-type match.

**NOTE:** To light gas grill with a fireplace-type match, follow steps 1 through 6 above. Remove cooking grid and flame tamer from burner you wish to light. Insert lighted fireplace-type match or long-necked butane lighter placing flame near to burner ports. Press in control knob and rotate left to "HIGH" setting to release gas. Burner should light immediately. If more than one burner is needed, repeat procedure with each burner. Replace flame tamer and cooking grid. Turn off burners not needed, and adjust other burners to desired cooking temperature.

### Lighting Rotisserie Burner (if equipped):

The rear infrared rotisserie burner allows for slow rotisserie cooking of meats and poultry. Infrared burners radiate heat onto the outer surface of the food. This allows cooking without the grease drippings burning on the flame tamers.

### To light Rotisserie Burner:

1. Always open lid before lighting.
2. Set ALL BBQ Grill control knobs to "OFF" and open gas supply, LP cylinder or Natural Gas Valve.
3. The rotisserie control knob is located at the middle of the Control Panel. Push in control knob completely and rotate slowly (5 to 10 seconds) about 1/4 turn to the left (counter clockwise) until a click is heard. The 5 to 10 second duration should provide enough gas to light the burner. If the burner does not light, immediately return the control knob to "OFF", wait several minutes for any accumulated gas to clear out of the grill.
4. Keep lid closed and operate burner at the "ON" position when using rotisserie.

**Note:** Rotisserie burner may take a few tries to ignite.

**WARNING: Never operate Rotisserie Burner with main burner(s) "ON"  
Warming Rack must be removed when operating the Rotisserie Burner**

**Do not attempt to regulate the rotisserie burner by using the control knob. This control has a fixed setting and is not adjustable.**

**NOTE:** Initially, the Ceramic Panel will have a blue flame that, after some time, will change to an orange flame and the Ceramic Panel will glow an orange color. *This may not be evident in bright daylight.*

**To light Rotisserie Burner with a fireplace-type match.** Follow steps 1 & 2 above. Carefully insert lighted fireplace-type match or long-necked butane lighter placing flame near to the Ceramic Panel. Press in control knob and rotate left (counter clockwise) to "HIGH" or "ON" setting to release gas. Burner should light immediately.

# LIGHTING & OPERATING INSTRUCTIONS (CONT.)

## Lighting Sideburner(s):

1. Check that the brass ring is properly located over each sideburner.
2. Always open lid before lighting.
3. Set ALL sideburner control knobs to "OFF" and open gas supply, LP cylinder or Natural Gas Valve.
4. Ignite only the sideburner you intend to use, using the same method for each: Push in control knob completely and rotate slowly (3 to 4 seconds) about 1/4 turn to the left (counter clockwise) until a click is heard. The 3 to 4 second duration should provide enough gas to light the sideburner. If the sideburner does not light, immediately return the control knob to "OFF", wait several minutes for the gas to disperse, and repeat the process. After sideburner ignites, repeat procedure with the secondary sideburner if needed.
5. Adjust control knob(s) to desired cooking temperature.

**NOTE: To light sideburner(s) with a fireplace-type match,** follow steps 1 through 3 above. Insert lighted fireplace-type match or long-necked butane lighter placing flame near to burner ports. Press in control knob and rotate left to "HIGH" setting to release gas. Sideburner should light immediately. If secondary sideburner is needed, repeat procedure. Adjust sideburner(s) to desired cooking temperature.

## ***OPERATING PROCEDURE***

**Burn-off:** Before cooking on your gas grill for the first time, burn the grill to get rid of any odors or foreign matter by igniting the burners, closing the lid, and operating at "HIGH" setting for about five minutes. You may then either set the controls to "OFF" or cook on your grill immediately by turning the control knobs to a lower setting.

**CAUTION: DO NOT LEAVE GRILL UNATTENDED WHILE IN USE.**

**Preheating:** It is necessary to preheat the grill for a short time before cooking certain foods, depending on the type of food and the cooking temperature. Food that requires a high cooking temperature needs preheat for five minutes; food that requires a lower cooking temperature needs only a period of two to three minutes. There is no need to preheat for casseroles or other foods that require slow cooking.

## ***COOKING TEMPERATURES***

**HIGH setting -** Use this setting only for fast warm-up, for searing steaks and chops, and for burning food residue from the cooking grids after the cookout is over.

**MEDIUM setting -** Use this setting for most grilling, roasting or baking, and for cooking hamburgers and vegetables.

**LOW setting -** Use this setting for all smoke cooking, rotisserie cooking, and when cooking very lean cuts such as fish.

**Note:** These temperatures vary with the outside temperature and the amount of wind.

**Cooking With Indirect Heat:** You can cook poultry and large cuts of meat slowly to perfection on one side of the grill by indirect heat from the next burner. The heat from the lighted burner circulates gently throughout the grill, cooking the meat or poultry without any direct flame beneath or below the food you are preparing. This method greatly reduces flare-ups when cooking extra fatty cuts, because there is no direct flame to ignite the fats and juices that drip down during cook-ing. Place a drip pan slightly smaller than the cut of meat on the cooking grids or flame tamer surface under the meat being cooked. This will allow you to catch meat juices for making gravy.

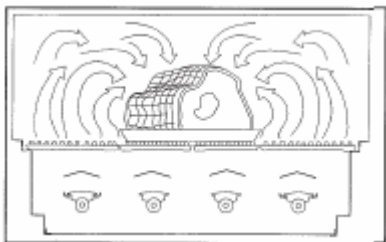

# LIGHTING & OPERATING INSTRUCTIONS (CONT.)

**Flare-Ups:** The fats and juices that drip from the meat cause flare-ups. Since flare-ups impart the distinctive taste and color for food cooked over an open flame, they should be expected and encouraged within reason. Nevertheless, uncontrolled flaring can result in a ruined meal. To control excessive flare-ups caused by too high a heat setting, turn the heat control knob to a lower setting.

**CAUTION:** If burners go out during operation, close gas supply at source, and turn all gas valves off. Open lid and wait five minutes before attempting to re-light (this allows accumulated gas fumes to clear).

**CAUTION:** Should a grease fire occur, close gas supply at source, turn off all burners and leave lid closed until fire is out. Do not use water or any liquid to extinguish a grease fire.

**CAUTION:** Do not attempt to disconnect any gas fitting while your barbecue is in operation or while gas feed is on.



# ROTISSERIE COOKING

Rotisserie is mostly used to cook large pieces of meat and poultry to assure slow, even cooking. The constant turning provides a self-basting action, making food cooked on a rotisserie exceptionally moist and juicy. Rotisserie cooking generally requires 1 ½ to 4 ½ hrs to cook depending on the size and type of meat being cooked. You can have rotisserie cooking with indirect heat as shown or with infrared rotisserie burner.

For successful roasting, the meat should be centered and balanced as evenly as possible on the spit rod to avoid overworking the rotisserie motor (see rotisserie kit assembly shown below).

Since indirect heat is often used in cooking on a rotisserie, a foil or aluminum drip pan is advisable to prevent excessive flare-ups. Generally, the cooking grills are removed to allow for the swing of the rotisserie. A basting pan is placed under the rotisserie area on top of the flame tamer(s) to catch the drippings.

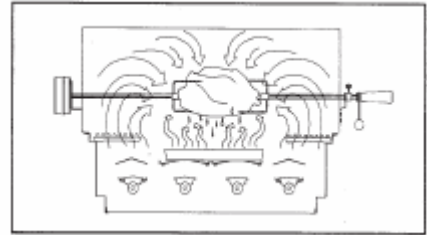

**WARNING: Never operate Rotisserie Burner with main burner(s) "ON"**  
**Warming Rack must be removed when operating the Rotisserie Burner**

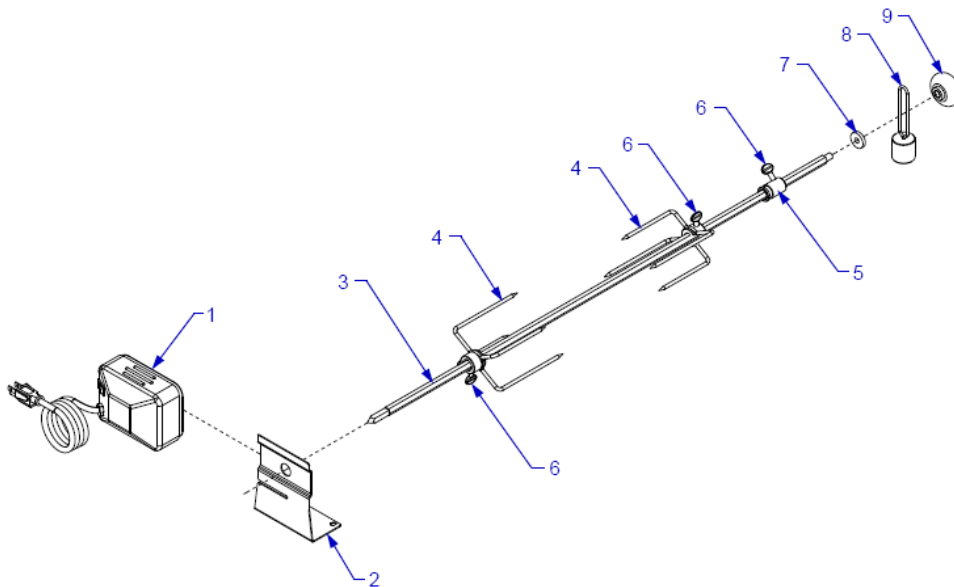

ROTISSERIE KIT		
Item No.	Qty	Description
1	1	110 VAC MOTOR W/ SWITCH
2	1	MOTOR MOUNT BRACKET
3	1	SPIT ROD
4	2	LARGE 4-PRONG SPIT FORK
5	1	SHAFT COLLAR
6	3	1/4-20 X 1/2 THUMBSCREW
7	1	KEY WASHER
8	1	COUNTER-BALANCE
9	1	BLACK PHENOLIC HANDLE

# ROTISSERIE COOKING (CONT.)

## LIGHTING & OPERATING INSTRUCTIONS

To install the motor bracket, remove the two (2) end screws on the grill closest to the front. Place bracket on top of grill lip and replace screws (see drawing to the right). Bracket can be installed on either side of the unit.

The meat should be centered and balanced as evenly as possible on the spit rod to avoid overworking the motor.

NOTE: To evenly balance the food on the spit rod, it is important to follow the directions as shown. The trolley thumb screw should be located on the inside of the grill, screw the knurled nut on next, the counter weight is then added and then screw on the black handle.

To adjust the counter-weight, loosen the black handle and slide the counter-weight up or down to properly position the weight of the food being cooked.

Since indirect heat is often used in cooking on a rotisserie, a foil or aluminum drip pan is advisable to prevent excessive flare-ups. If more space is needed when using the rotisserie, remove the cooking grates and place the drip pan on the flame tamers. You may wish to add beer, wine or water to pan.

It is advisable to load rotisserie with meat to be cooked before turning on gas to check to see that the spit rod is turning properly without any unnecessary strain on the motor. Then light infrared burner.

NOTE: TO LIGHT INFRARED BURNER, TURN KNOB AND WAIT ABOUT 10 SECONDS TO ALLOW GAS TO GET TO BURNER BEFORE CLICKING IGNITION KNOB.

**ALWAYS LIGHT THE GRILL WITH THE HOOD IN AN OPEN POSITION!**

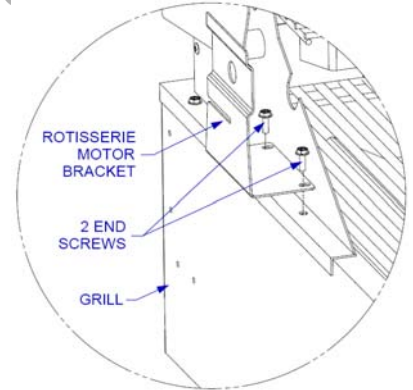

# LIGHT SYSTEM

## LIGHT BULB REPLACEMENT

If light bulb(s) need to be replaced, make sure power is disconnected and grill and light bulbs are completely cool to the touch.

1. Remove screw with a small Phillips screwdriver. Caution: Glass cover may be loose, ensure the cover is properly supported before completely removing the screw.
2. There is a metal clip that clamps onto the glass cover and snaps into the light housing on the screw end. Unsnap the cover by carefully prying apart the metal clip from the light bulb housing. Once unsnapped, slide the cover out and away from the housing and set somewhere safe.

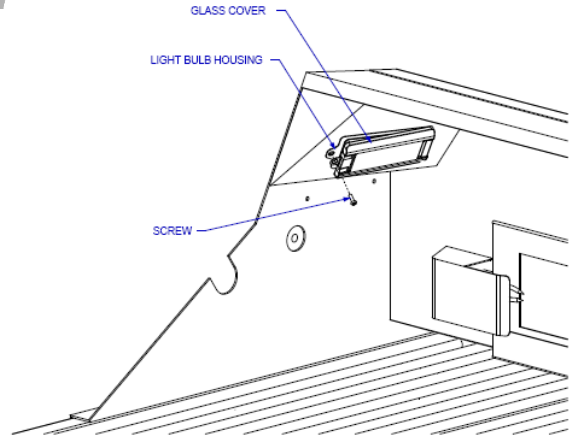

3. Remove old light bulb by pulling the bulb out of the housing (make sure bulb is cool before removal).

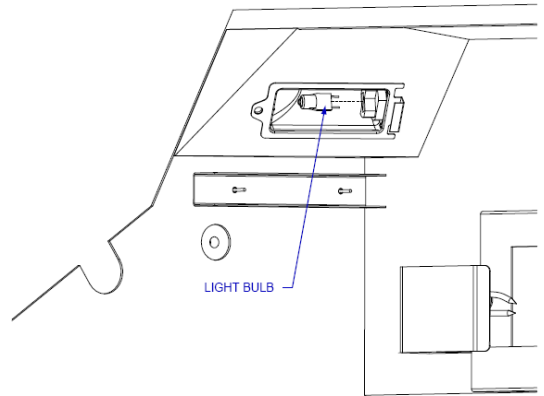

## LIGHT SYSTEM (CONT.)

4. Using a soft cloth or paper towel, replace new light bulb into the housing (finger prints left on the bulb may reduce its life). Make sure the metal prongs on the light bulb slip into the openings in the light housing.

**BULL**  
Outdoor Products Inc.

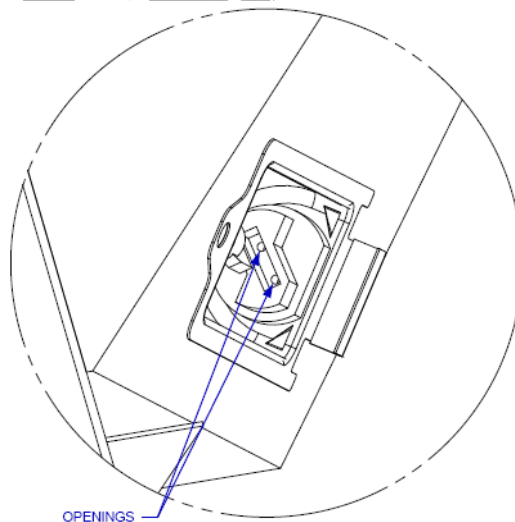

5. Replace glass cover and re-snap metal clip into light housing. Replace screw and tighten. To replace the other bulb, follow the same procedure.

# CLEANING & MAINTENANCE

## CLEANING THE COOKING GRIDS

After cooking, turn control knobs to "OFF" and let grill cool before attempting to clean your cooking grids. Before first use and periodically it is suggested that you wash the cooking grids in a mild soap and warm water solution. You can use a washcloth or a vegetable brush to clean your cooking grids.

## CLEANING THE FLAME TAMERS & HEAT SHIELDS *Products Inc.*

Washing the flame tamers & heat shields after every use is not necessary but periodically it is suggested you wash them in a soap and warm water solution. Use a wire brush to remove stubborn burned on cooking residue. Dry the flame tamers & heat shields thoroughly before you reinstall it in the cooking insert.

## CLEANING THE BURNERS

**IMPORTANT:** Gas control knobs should be in the "OFF" position, and fuel line should be disconnected from gas valve manifold. To reduce the chance of FLASHBACK, the procedure below should be followed at least once a month or when your grill has not been used for an extended period of time.

1. Remove burners from grill by carefully lifting each burner up and away from gas valve orifice.
2. Wire brush entire outer surface of burner to remove food residue and dirt. Clean any clogged ports with a stiff wire such as an open paper clip.
3. Inspect the burner for damage (cracks or holes) and if such damage is found, order and install a new burner.
4. After installation, check to insure that gas valve orifices are correctly placed inside ends of burner tubes. Also check position of spark electrode.

## CLEANING THE GREASE TRAY

The grease tray should be emptied and wiped down periodically and washed in a mild detergent and warm water solution.

## ANNUAL CLEANING OF GRILL HOUSING

Burning-off the grill after every cookout will keep it ready for instant use. However, periodically the grill should be given an entire thorough cleaning to ensure optimal performance.

1. Shut off gas supply at source and disconnect fuel line from gas valve manifold. Protect fuel line fitting.
2. Remove and clean (as explained above) the cooking grids, flame tamers and burners.
3. Remove warming rack and wash with mild detergent and warm water.
4. Cover the gas valve orifices with a piece of aluminum foil.
5. Brush the inside and bottom of the grill with a stiff wire brush, and wash down with a mild soap and warm water solution. Rinse thoroughly and let dry.
6. Remove aluminum foil from orifices and check orifices for obstruction.
7. Check electrode as instructed on page 10.
8. Replace flame tamers, cooking grids, and warming rack.
9. Reconnect to gas source and observe burner flame for correct operation.

**IMPORTANT:** You should NOT line the bottom of the grill housing with aluminum foil, sand or any other grease absorbent substance. Grease will not be able to drip down into grease collector and a grease fire could occur.

## STAINLESS STEEL CLEANING AND MAINTENANCE

Stainless steel is a corrosion resistant chromium/nickel alloy steel that is both durable as well as strong with an outstanding luster. The goal of your cleaning and maintenance routine should be to keep the stainless steel's protective chromium oxide layer intact. This is what prevents corrosion. Contrary to popular belief, stainless steel is NOT rustproof, especially in the environment of a swimming pool. Chlorine, bromine, some fertilizers and other elements are extremely caustic chemicals for stainless steel. These chemicals combined with heat and humidity greatly increase the corrosiveness of these chemicals. Regular cleaning is the best way to prevent corrosion and add years of enjoyment to your Bull stainless steel products.

# TROUBLESHOOTING

## IF GRILL FAILS TO OPERATE PROPERLY

# BULL



1. Turn off gas at source, turn control knobs to "OFF", and wait five minutes before trying again.
2. Check gas supply/connections.
3. Repeat lighting procedure.

*Outdoor Products Inc.*

If grill still fails to operate properly, **TURN "OFF" GAS AT SOURCE, TURN CONTROL KNOBS TO "OFF"**, wait for grill to cool, and check the following:

### a. Misalignment of burner tube(s) over orifice(s)

**CORRECTION:** Reposition burner tube to properly seat over orifice.

### b. Obstruction in gas line

**CORRECTION:** Remove fuel line from grill. **DO NOT SMOKE!** Open gas supply for one second to blow any obstruction from fuel line. Close off gas supply at source and reconnect fuel line to grill.

### c. Plugged orifice

**CORRECTION:** Remove cooking grids, flame tamers and grease tray. Remove burners from bottom of grill insert by pulling cotter pin from beneath burner peg using a screwdriver or needle nose pliers (Please reference the diagram on page 9). Carefully lift each burner up and away from gas valve orifice. Remove the orifice from each burner up and away from gas valve and gently clear any obstruction with a fine wire. Re-install each orifice, re-install burners over orifices and seat each burner peg into mounting bracket at bottom of grill insert. There is no need to replace the cotter pins, they are for shipping purposes only. Replace cooking components and grease collectors. If an obstruction is suspected in gas valve(s) or gas valve bracket, please contact your gas grill dealer or gas appliance service person for assistance.

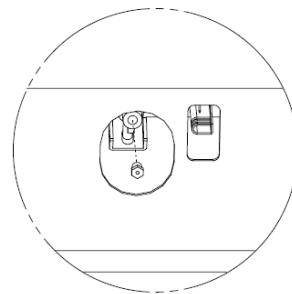
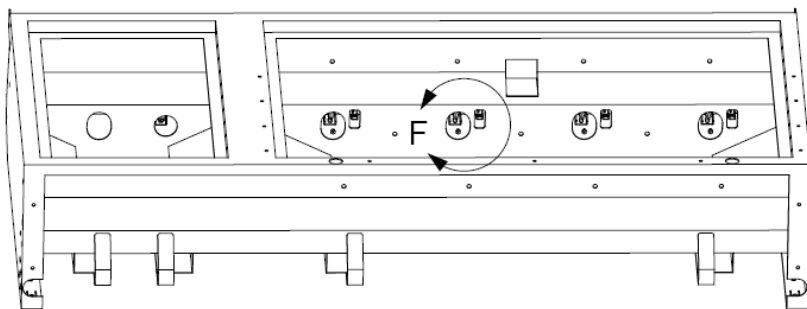

Detail F

### d. Misalignment of igniter on burner

**CORRECTION:** Check for proper position of electrode tip. The tip of the electrode should be pointing forward toward the front and free from grease for spark discharging. The ignition wire should be firmly connected to the valve ignition and electrode. Replace the ignition wire if the wire were broken or cracked. With gas supply closed and all control knobs set to "OFF", check each positive igniter individually for presence of spark at electrode. In turn, push each control knob in fully and rotate about 1/4 turn to the left (counter-clockwise) until click is heard; the trigger hitting the strike block should produce a blue spark at the electrode tip. Return control knob to "OFF" before checking next igniter.

### If re-ignition is necessary

While the gas grill is still hot, you must wait for a minimum of five minutes before commencing to re-ignite (this allows accumulated gas fumes to clear). If all checks/corrections have been made and gas grill still fails to operate properly, consult your grill dealer or gas appliance service person.

# TROUBLESHOOTING (CONT.)

## *YELLOW FLAME*

Once the entire burner is operating, check the flame color to be sure it is mostly blue (some yellow color will be present because of impurities in the fuel). If the flame is golden or yellow in color the reason could be seasoning salts, oil film, or other foreign matter on burner.

**CORRECTION:** Either wash burner with mild detergent, or operate burner at "HIGH" setting with lid closed for about 10 minutes.

## *FLASH BACK*

When fire occurs in and around the burner tubes, immediately turn off gas at its source and turn the control knob(s) to "OFF". Wait until the grill has cooled, then clean the burner tubes and burner ports as described on page 9.

# PARTS LIST

MODEL #18248 BULL 7 BURNER STAINLESS STEEL, ROTISSERIE, BUILT-IN, L.P. (PROPANE)  
 MODEL #18249 BULL 7 BURNER STAINLESS STEEL, ROTISSERIE, BUILT-IN, N.G. (NATURAL GAS)

REF #	PARTS #	DESCRIPTION	QTY	WARRANTY PERIOD
1	18001	LID - FRONT	1	1 yr
2	18002	LID - REAR	1	1 yr
2A	18014	COVER - REAR LID	1	1 yr
3	18004	INSERT ASSEMBLY	1	Lifetime
4	18012	CONTROL PANEL	1	1 yr
5	18007	GREASE TRAY - MAIN BURNER	1	1 yr
5A	18046	GREASE TRAY - SIDEBURNER	1	1 yr
6	16520	HEAT SHIELD	3	3 yrs
7	16516	CAST STAINLESS STEEL BURNER	4	20 yrs
8	16521	FLAME TAMER - MAIN BURNER	4	3 yrs
8A	18005	FLAME TAMER - SMOKER BOX	1	3 yrs
9	16517	COOKING GRATE	4	Lifetime
10	18003	WARMING RACK	1	3 yrs
11	16523	LID HANDLE	1	3 yrs
12	16501	BEZEL - MAIN BURNER	4	1 yr
12A	16502	BEZEL - BACK BURNER	1	1 yr
12B	16501	BEZEL - SIDEBURNER	2	1 yr
13	16505	KNOB - MAIN BURNER	4	1 yr
13A	16506	KNOB - BACK BURNER	1	1 yr
13B	16543	KNOB - SIDEBURNER	2	1 yr
14	16509	TEMPERATURE GAUGE	1	1 yr
15	18037(LP) / 18036(NG)	GAS VALVE - MAIN BURNER	4	1 yr
15A	60103	GAS VALVE - BACK BURNER	1	1 yr
15B	18044(LP) / 18045(NG)	GAS VALVE - SIDEBURNER	2	1 yr
16	16507	REGULATOR - NATURAL GAS MODEL ONLY	1	1 yr
16A	16508	REGULATOR - LIQUID PROPANE MODEL ONLY	1	1 yr
17	16599	REGULATOR ADAPTER - NATURAL GAS MODEL ONLY	2	1 yr
17A	16598	REGULATOR ADAPTER - LIQUID PROPANE MODEL ONLY	1	1 yr
18	*18006	MANIFOLD	1	3 yrs
19	*47006	STAINLESS FLEX TUBE 18"	1	1 yr
20	*18014	INFRARED ROTISSERIE BURNER	1	1 yr
21	*16534	TRANSFORMER	1	1 yr
22	18033	BACK PANEL	1	1 yr
23	*47009	BACK BURNER STAINLESS FLEX TUBE 39"	1	1 yr
24	*16527(LP) / *16528(NG)	NOZZLE - BACK BURNER	1	1 yr
25	16512	BACK BURNER IGNITION WIRE	1	1 yr
26	16511	ELECTRODE	1	1 yr
27	16569	BACK BURNER SHUTTER CLIP	1	1 yr
28	*16533	LIGHT SWITCH	1	1 yr
29	*16531	LIGHT HOUSING	2	1 yr
30	*16530	LIGHT LENS	2	1 yr
31	*16529	LIGHT LENS CLIP	2	1 yr
32	16532	LIGHT BULB	2	N/A
33	16539	SIDEBURNER BRASS BURNER	2	3 yrs
34	18042	SIDEBURNER COOKING GRATE	2	1 yr
35	18041	SIDEBURNER LID	1	1 yr
36	18040	SIDEBURNER LID HANDLE	1	1 yr
37	18049	SIDEBURNER IGNITION WIRE (SHORT)	1	1 yr
38	18050	SIDEBURNER IGNITION WIRE (LONG)	1	1 yr
39	16541	VENTRI TUBE	2	1 yr
40	18051(LP) / 18052(NG)	DOUBLE SIDEBURNER ORIFICE	2	1 yr
41	18047	SIDEBURNER STAINLESS FLEX TUBE (SHORT)	1	1 yr
42	18048	SIDEBURNER STAINLESS FLEX TUBE (LONG)	1	1 yr
43	18016	TRIM KIT	1	N/A
44	18013	SMOKER BOX	1	N/A

Any item with an \* next to it requires a serial number

## HOW TO ORDER REPLACEMENT PARTS

Please refer to the parts list on this page.

To make sure you obtain the correct replacement parts for your gas grill, the following information is required to assure getting the correct part.

1. Gas grill model number (see data sticker on grill) and type of gas hook up.
2. Reference number of replacement part needed.
3. Description of replacement part needed.
4. Quantity of parts needed.





# PARTS LIST (CONT.)

**IMPORTANT:** Use only factory authorized parts. The use of any part that is not factory authorized can be dangerous. This will also void your warranty.

**IMPORTANT:** Keep this assembly and operating instruction manual for referral, and for replacement parts ordering.

**CAUTION:** Gas valves are preset at the factory. If you wish to convert at some later date, be sure to contact your gas supplier or grill dealer before making the conversion.

**CAUTION:** A different gas valve must be installed when converting from one type of gas to another. You will also need a data plate indicating what type of gas the grill uses.

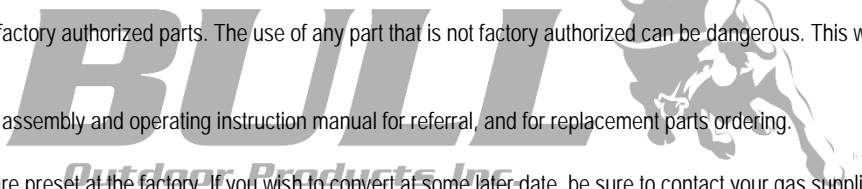

# EXPLODED ILLUSTRATION

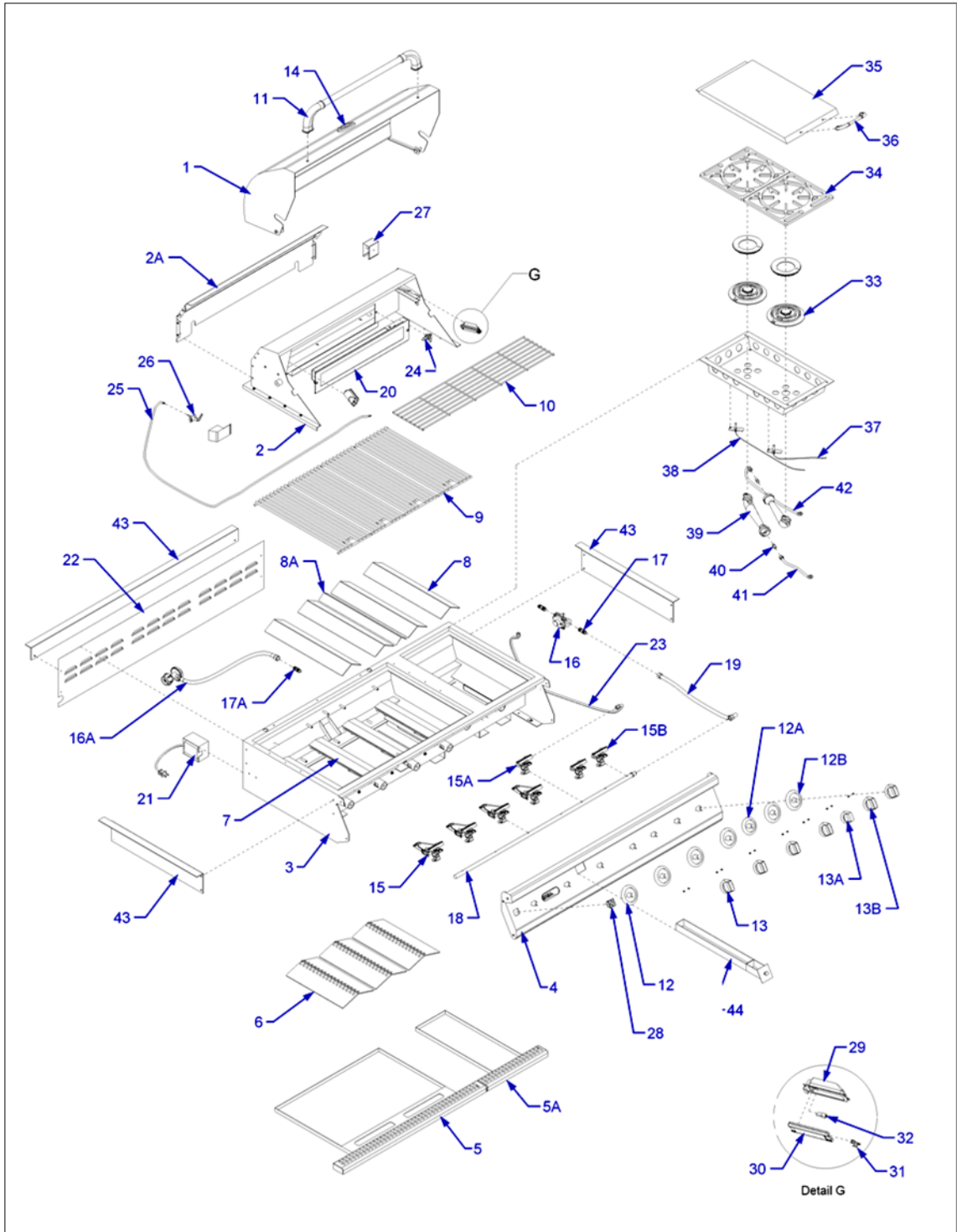

# LIMITED WARRANTY

Bull Outdoor Products, Inc. warrants to the original purchaser at the original site of delivery with proof of purchase of each Outdoor Gas Grill that when subject to normal residential use, it is free from defects in workmanship and materials for the periods specified below. This warranty excludes grills used in rental or commercial applications. It does not apply to rust, corrosion, oxidation or discoloration, which may occur due to moisture or overheating, unless the affected component becomes inoperable. It does not cover labor or labor related charges. There will be a shipping and handling charge for the delivery of the warranty part(s).

*Bull Outdoor Products Inc.*

Our obligation under this warranty is limited to repair or replacement, at our option, of the product during the warranty period. The extent of any liability of Bull Outdoor Products, Inc., under this warranty is limited to repair or replacement. This warranty does not cover normal wear of parts, damage resulting from any of the following: negligent use or misuse of the product, use on improper fuel/gas supply, use contrary to operating instructions, or alteration by any person other than our factory service center. The warranty period is not extended by such repair or replacement.

**Warranty claim procedure:** If you require service or parts for your Bull grill, please contact our Warranty Service Center for factory direct assistance. Our hours of operation are 8AM to 4 PM PST. Our phone number is (800) 521-2855 and our FAX number is (909) 770-8627. Please direct all correspondence to: **Bull Outdoor Products, Inc., 2483 W. Walnut Ave., Rialto, CA 92376. ATTN: Warranty Service Center**

Product repair as provided under this warranty is your exclusive remedy. Bull Outdoor Products, Inc. shall not be liable for any incidental or consequential damages for breach of any express or implied warranty on its products. Except to the extent prohibited by applicable law, any implied warranty or merchantability or fitness for a particular purpose on this product to the duration of the above warranty. Some states do not allow the exclusion or limitation of incidental or consequential damages, or allow limitations on how long an implied warranty lasts, so the above limitations or exclud-sions may not apply to you. This warranty gives you specific legal rights, and you may have other rights, which vary from state to state.

*Model Number* \_\_\_\_\_

*Serial Number* \_\_\_\_\_

*Date of Purchase* \_\_\_\_\_

*\*Attach a copy of your receipt or invoice here\**

