

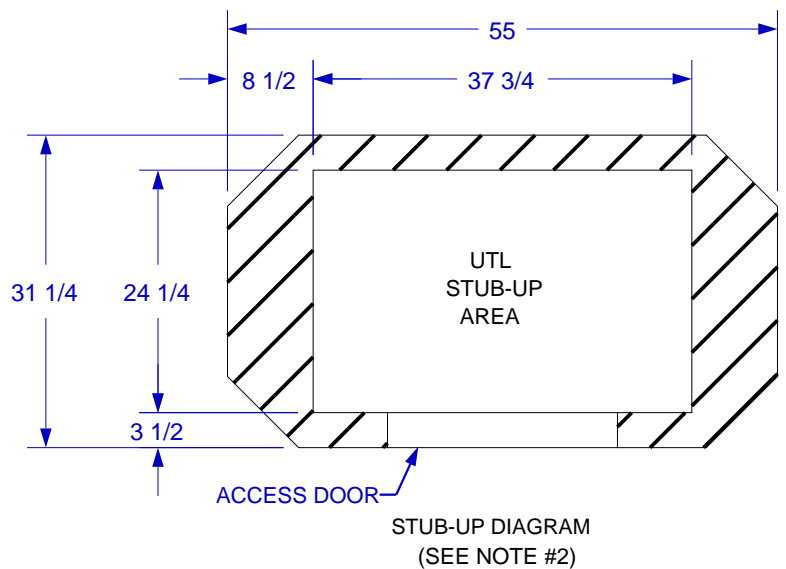

ANGLED RECTANGULAR FIRE PIT SPEC SHEET

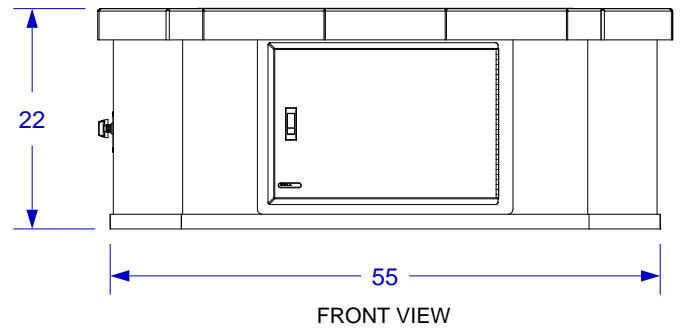
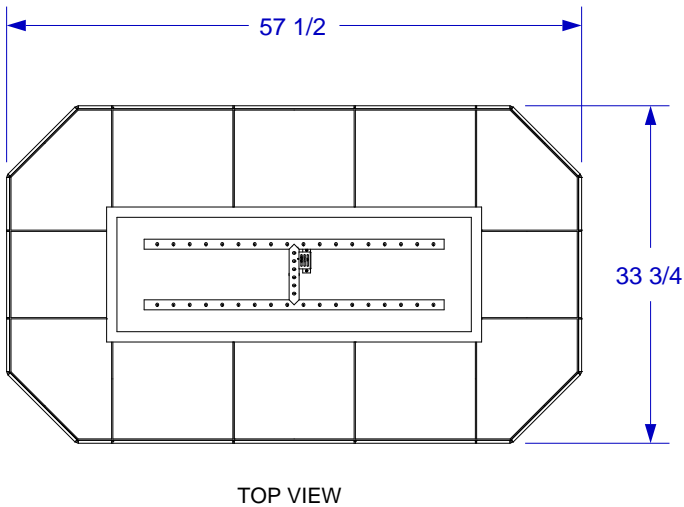
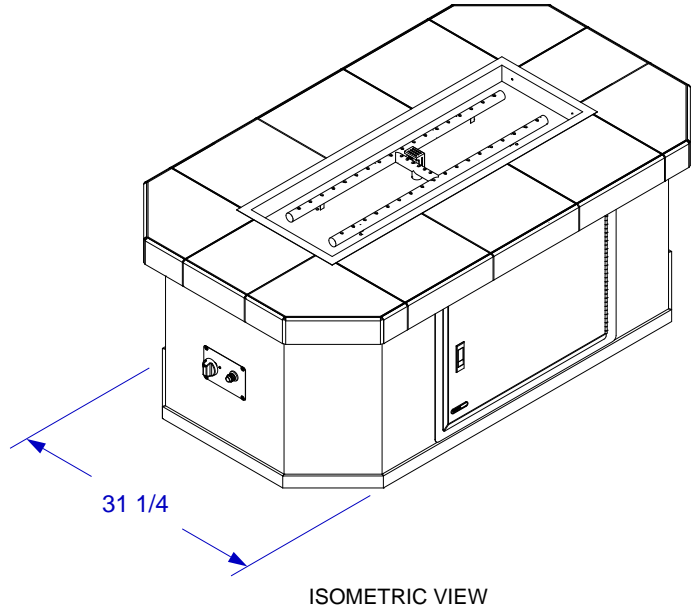

- NOTES:
1. FOR ROCK FINISHES, ADD 1 1/2" ON ALL BASE SIDES.
 2. 6" MAX HEIGHT ON ALL STUB-UPS.
 3. SCALE: 5/8" = 1'-0"